

27. 螺紋標準牙山的形狀

■ 公制螺紋(M)

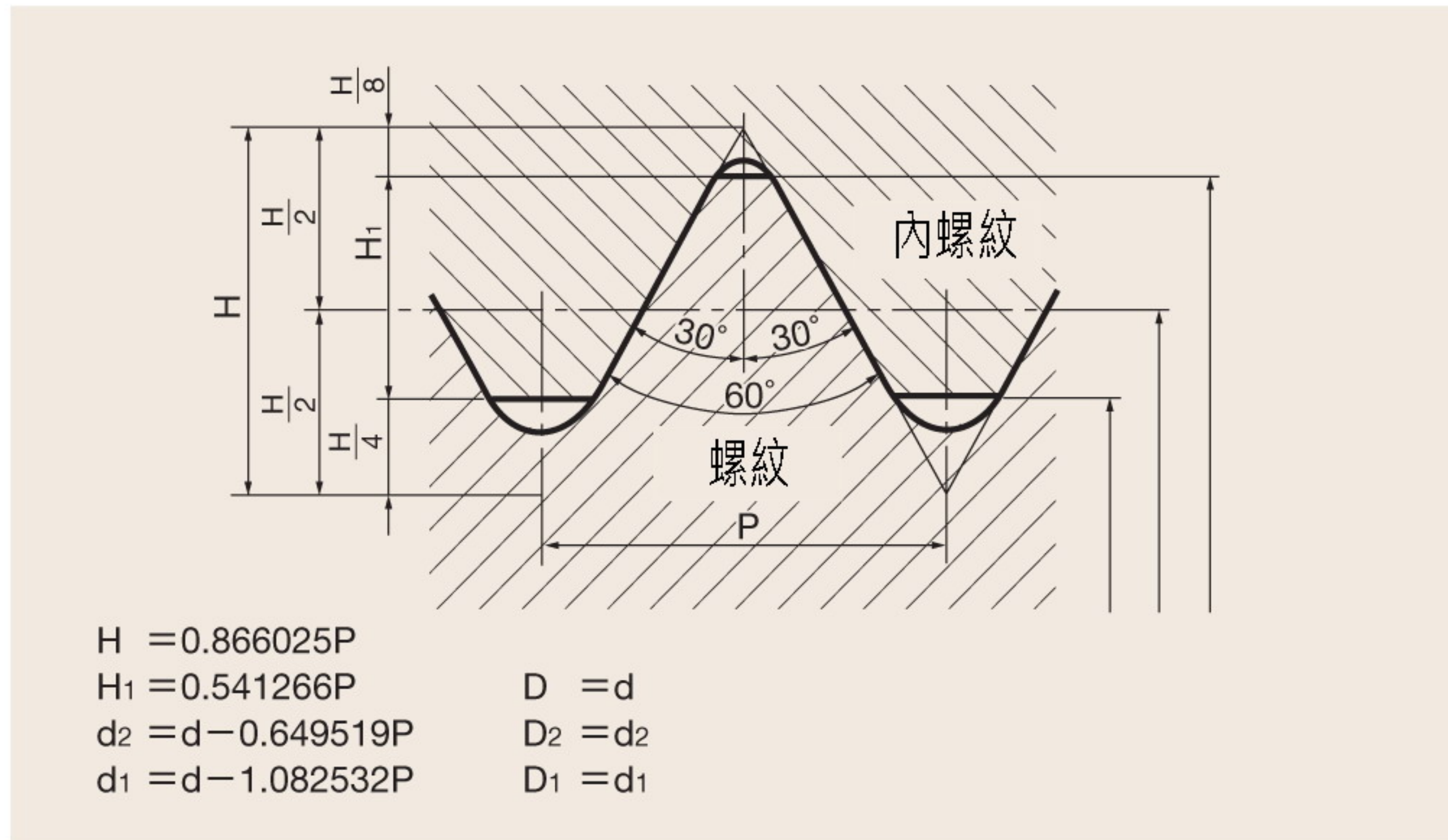

■ 美制螺紋(UNC, UNF, 其他)

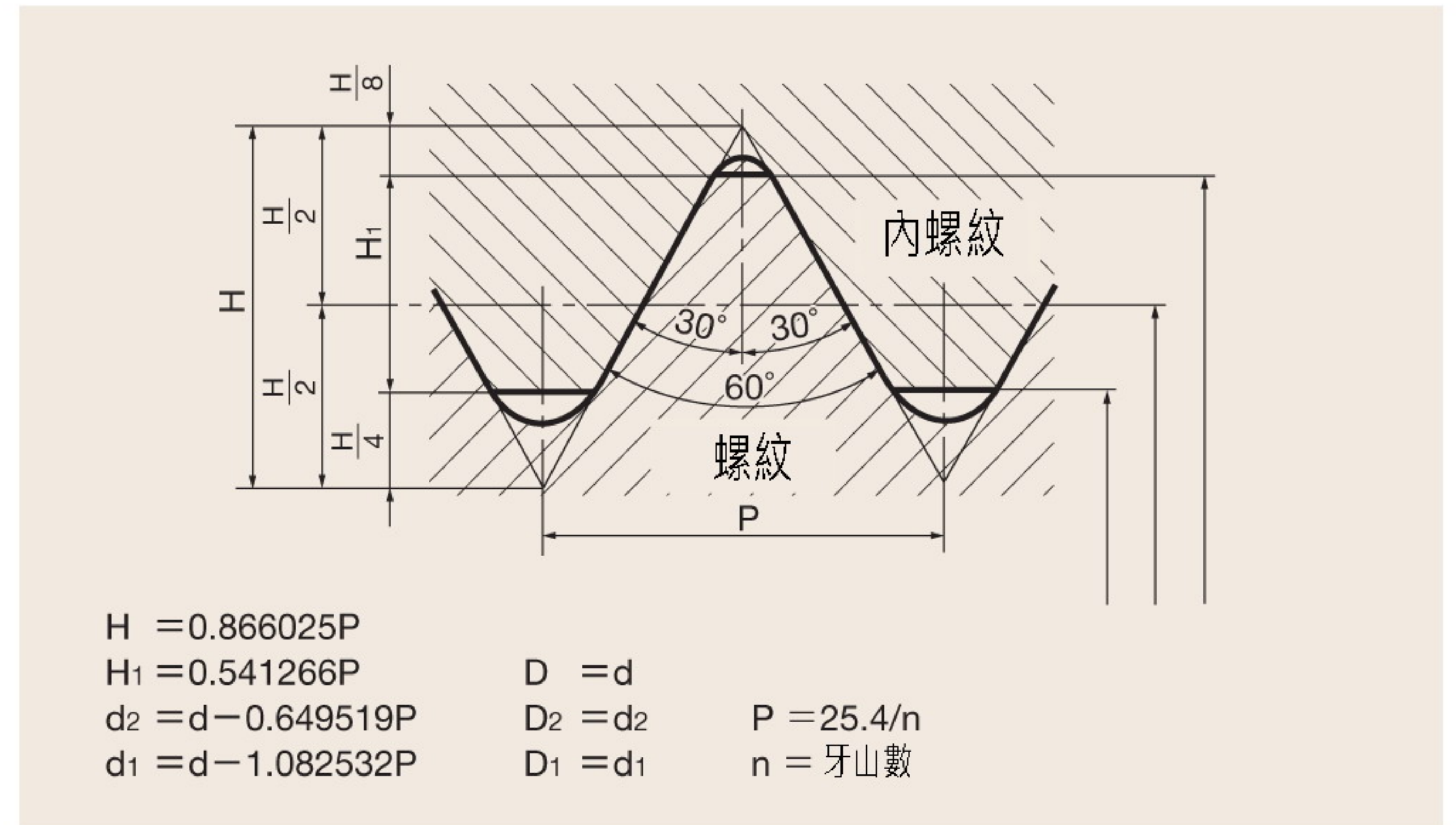

■ 英制螺紋(W)

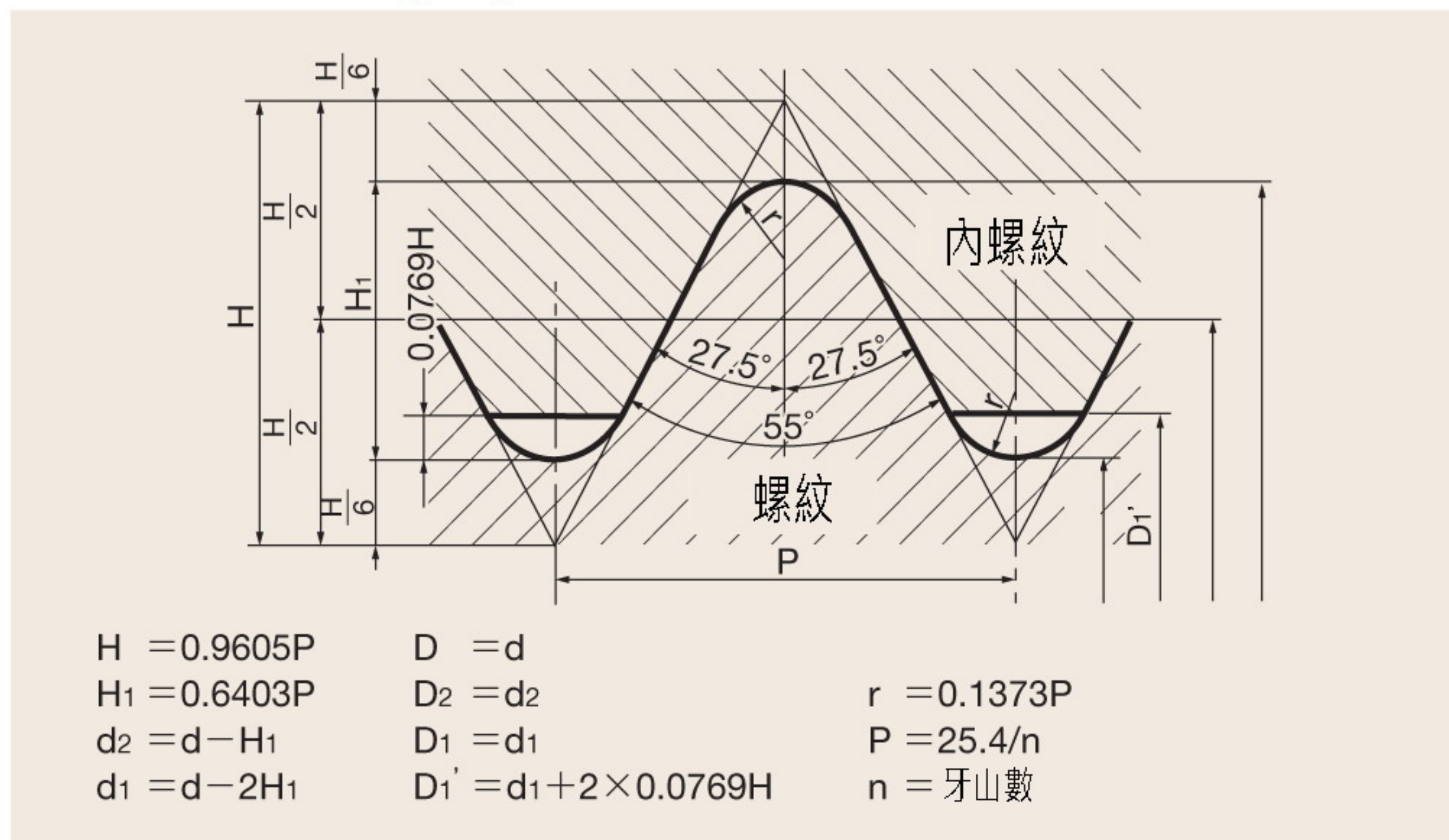

■ 針車牙(SM)

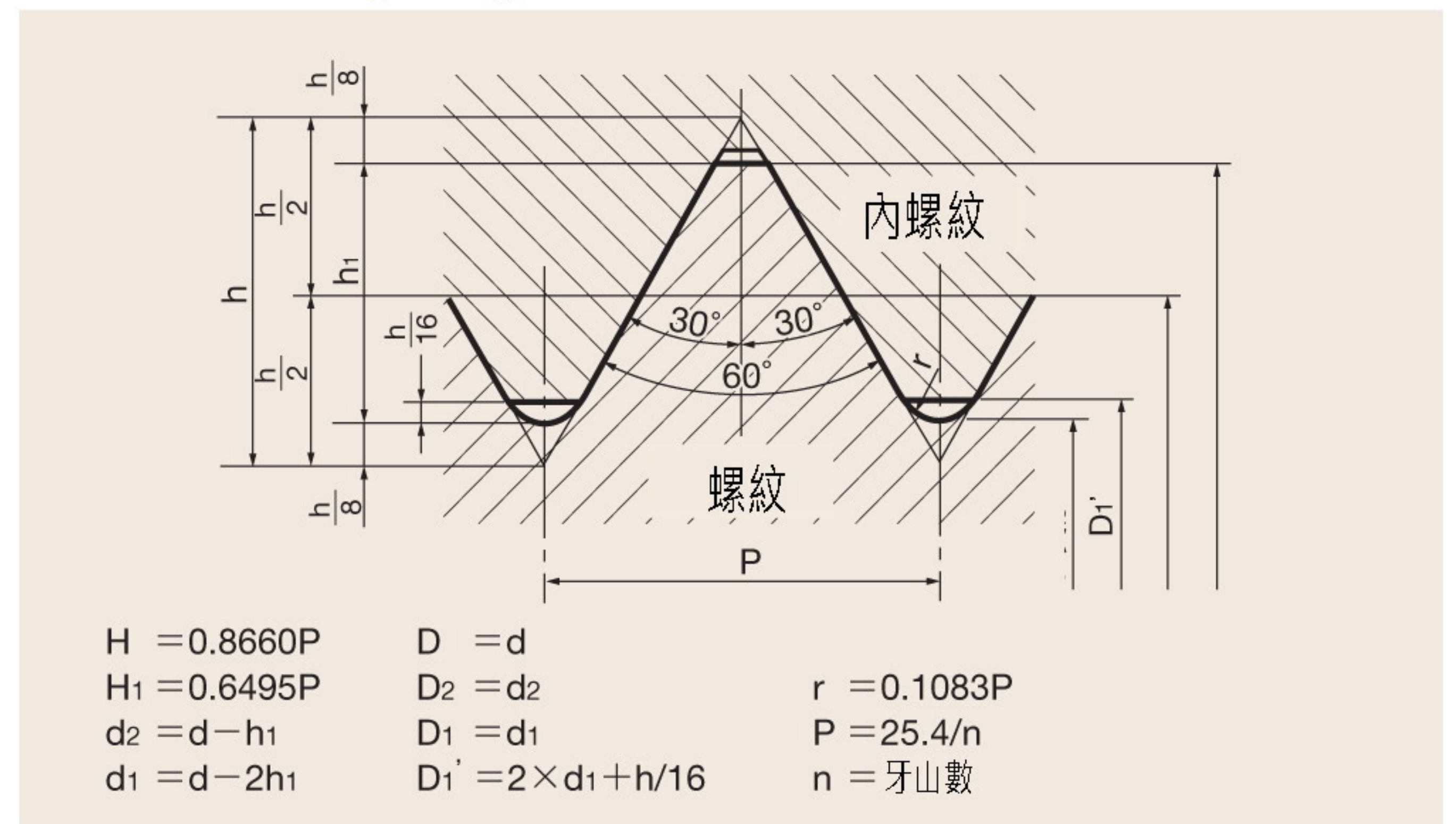

■ 小型螺紋(S)

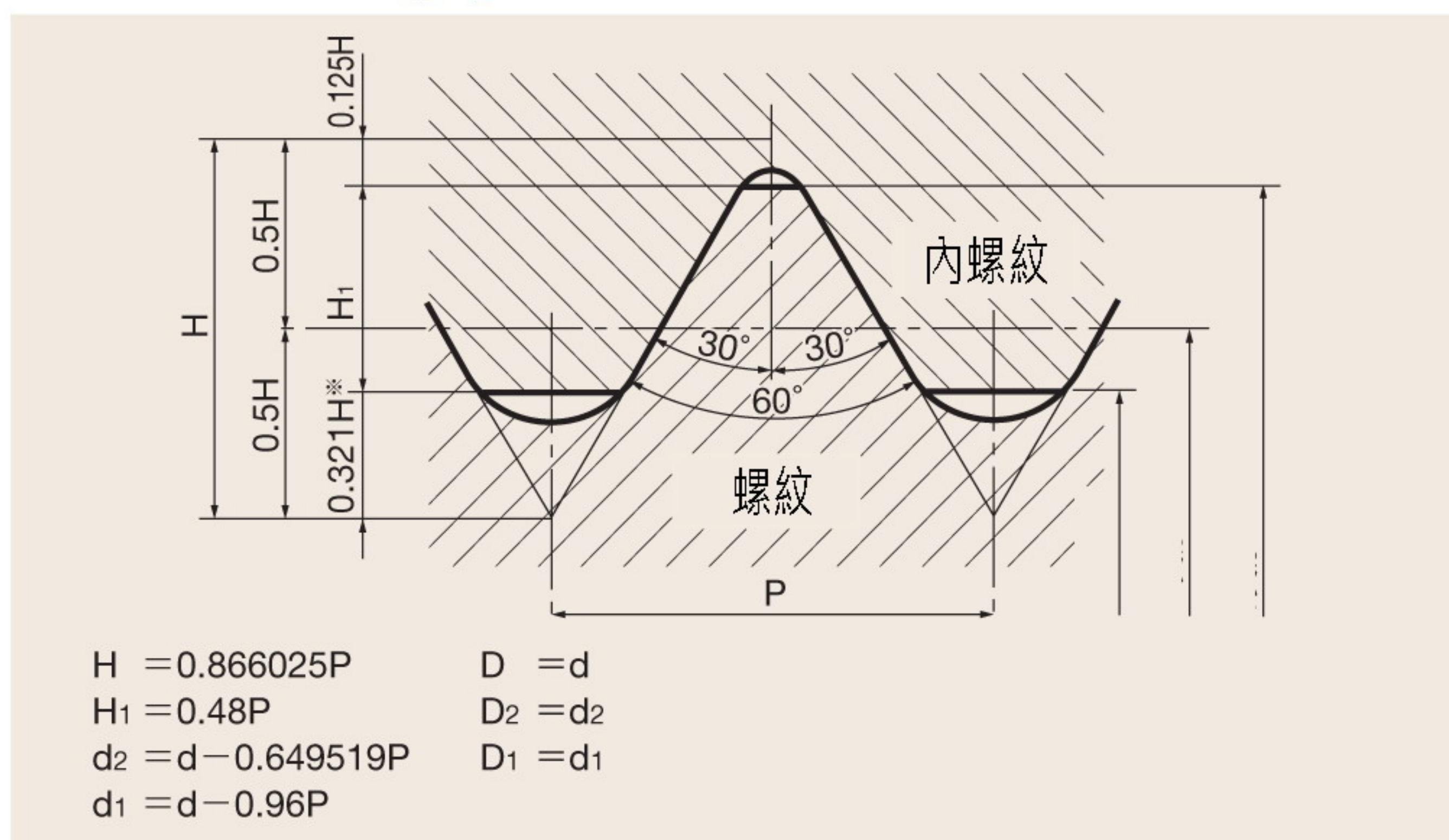

■ 管用平行螺紋(G, PF)

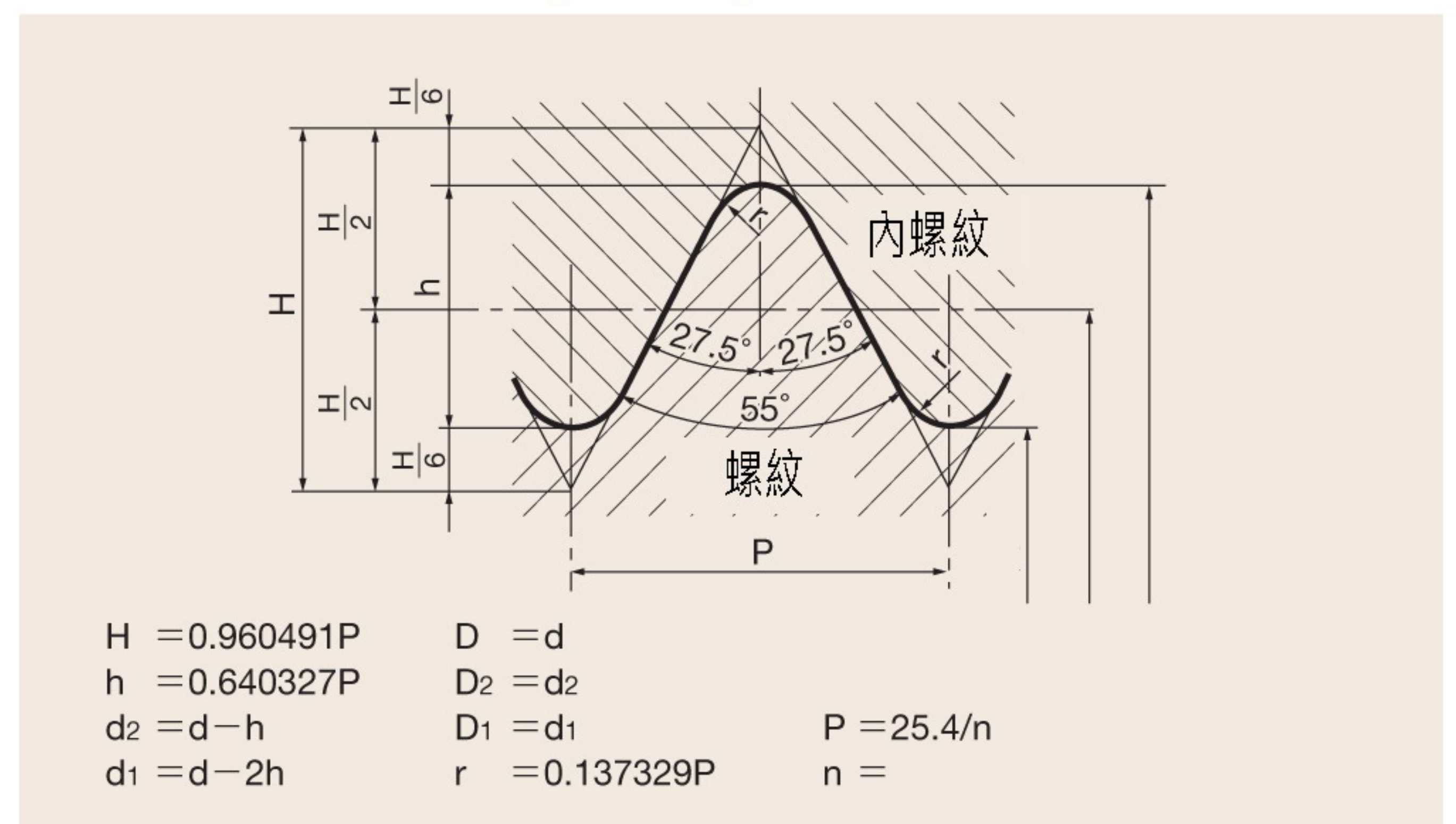

■ 管用推拔螺紋(R, Rc, PT)

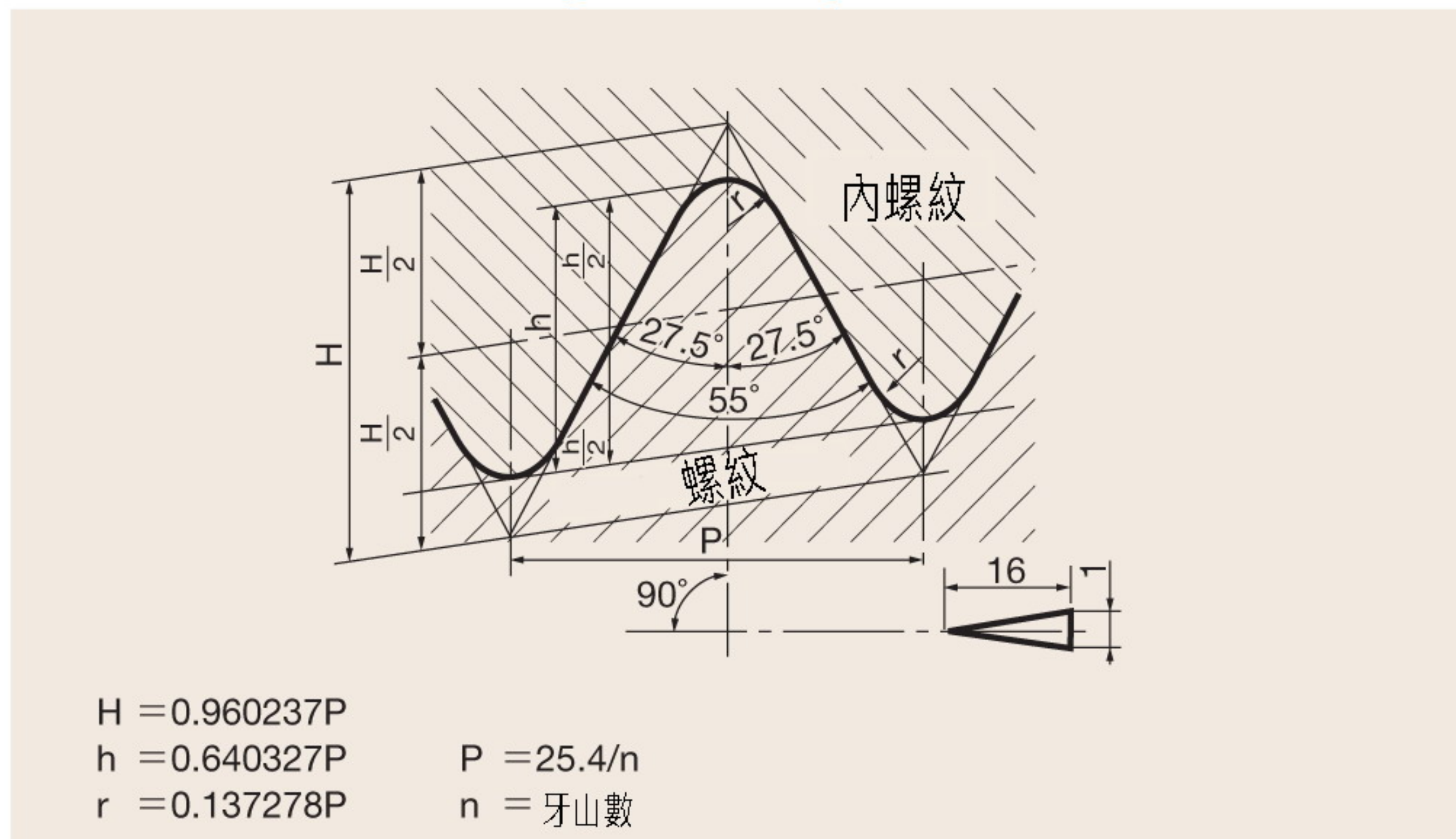

■ 管用推拔平行螺紋(Rp, PS)

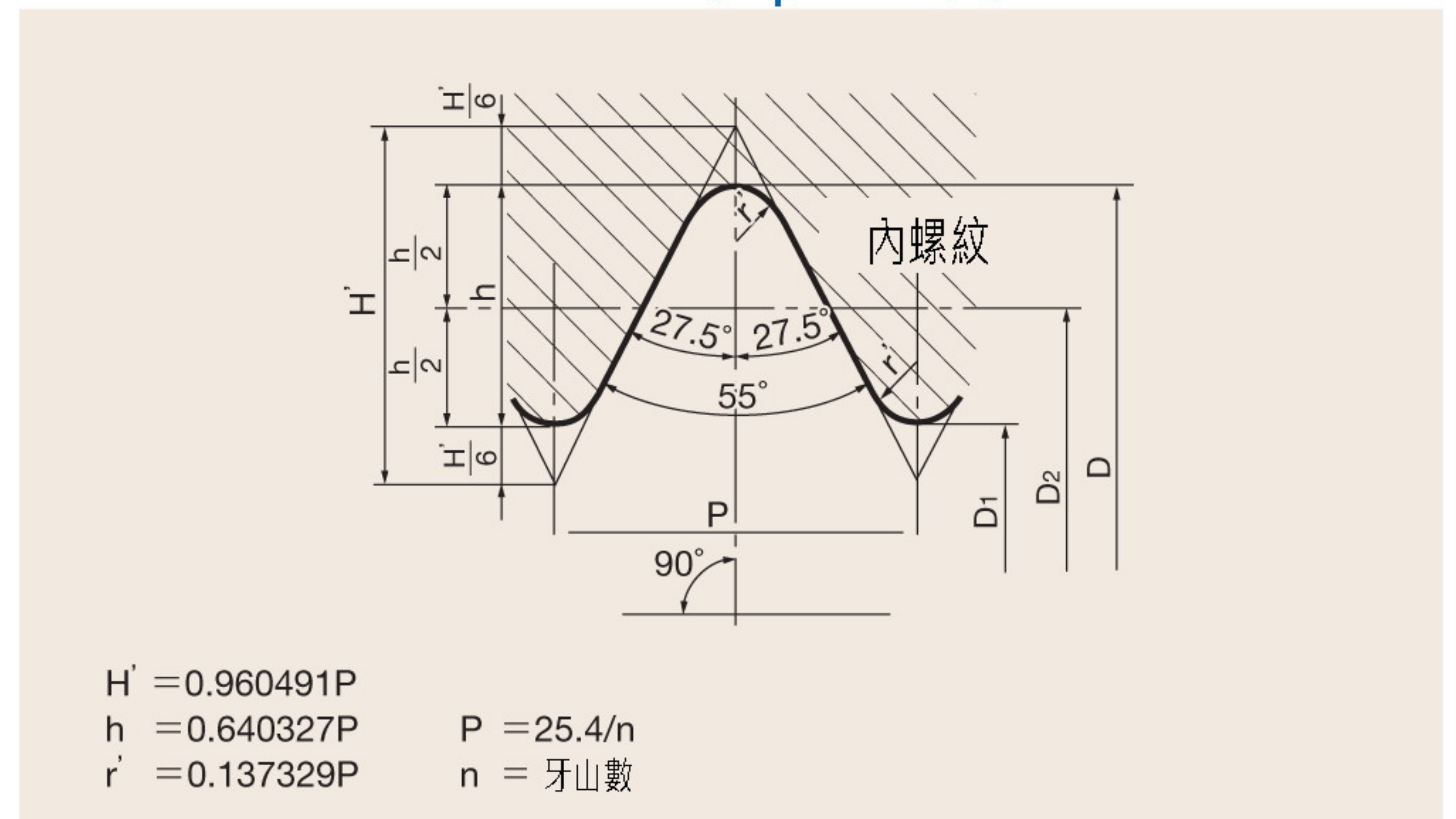

27. 螺紋標準牙山的形狀

■ 美製管用推拔螺紋 (NPT)

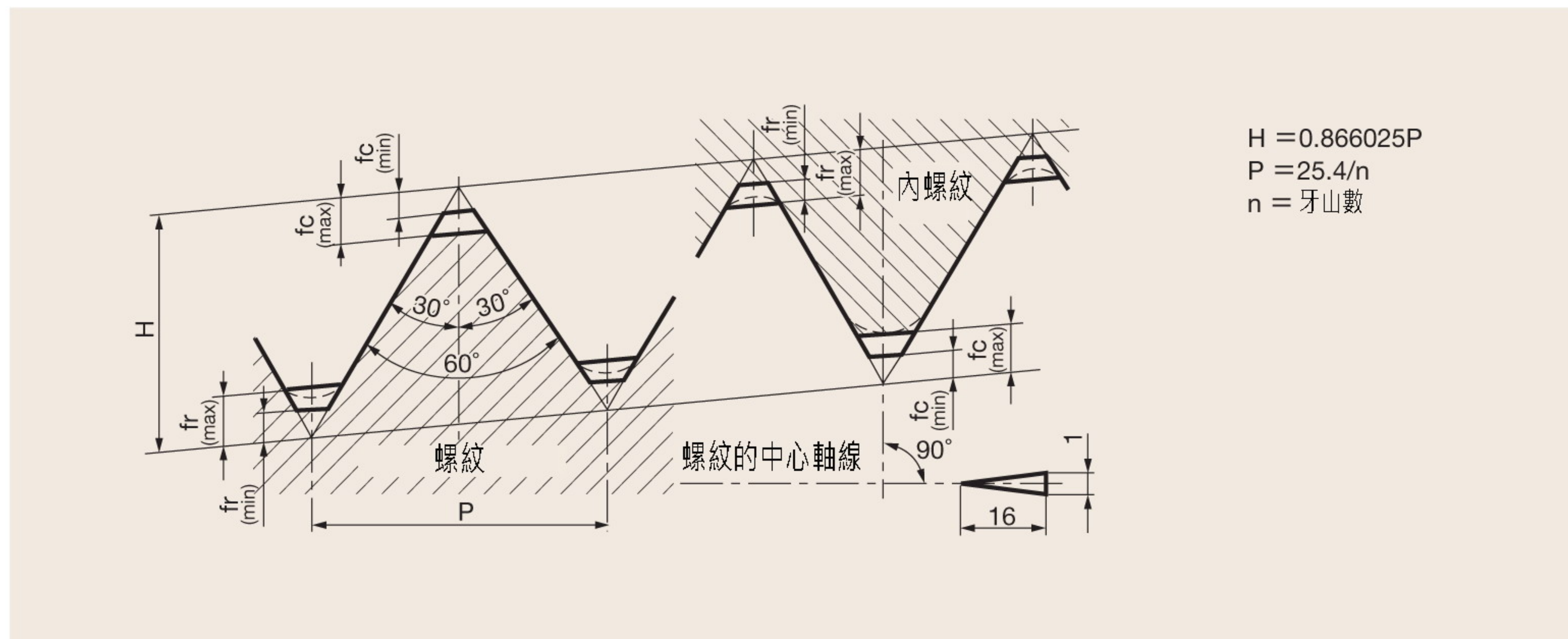

切口高度		單位
牙山數	區分	$fc=fr$
27	Max.	0.096P
	Min.	0.033P
18	Max.	0.088P
	Min.	0.033P
14	Max.	0.078P
	Min.	0.033P
11.5	Max.	0.073P
	Min.	0.033P
8	Max.	0.062P
	Min.	0.033P

■ 美製乾式氣密管用推拔螺紋 (NPTF)

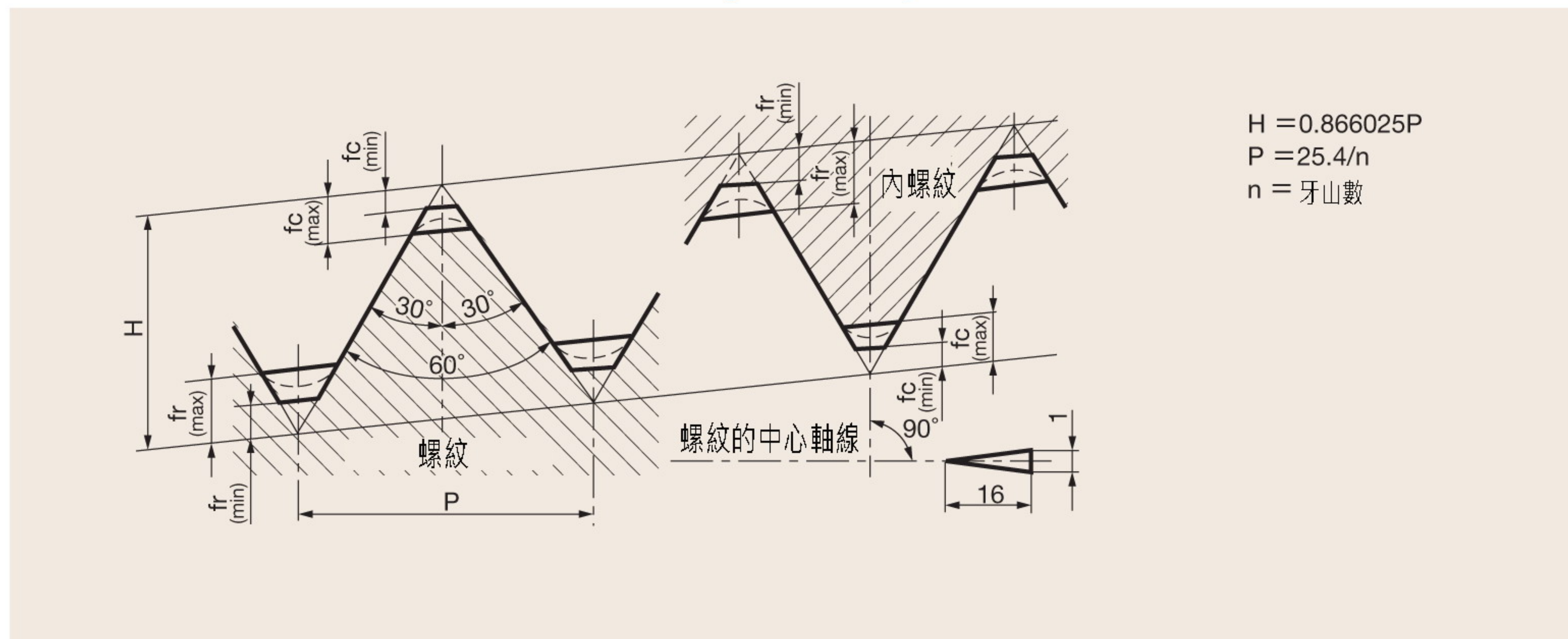

切口高度		單位	
牙山數	區分	fc	
27	Max.	0.094P	0.140P
	Min.	0.047P	0.094P
18	Max.	0.078P	0.109P
	Min.	0.047P	0.078P
14	Max.	0.060P	0.085P
	Min.	0.036P	0.060P
11.5	Max.	0.060P	0.090P
	Min.	0.040P	0.060P
8	Max.	0.055P	0.076P
	Min.	0.042P	0.055P

■ 公制梯形螺紋 (Tr)

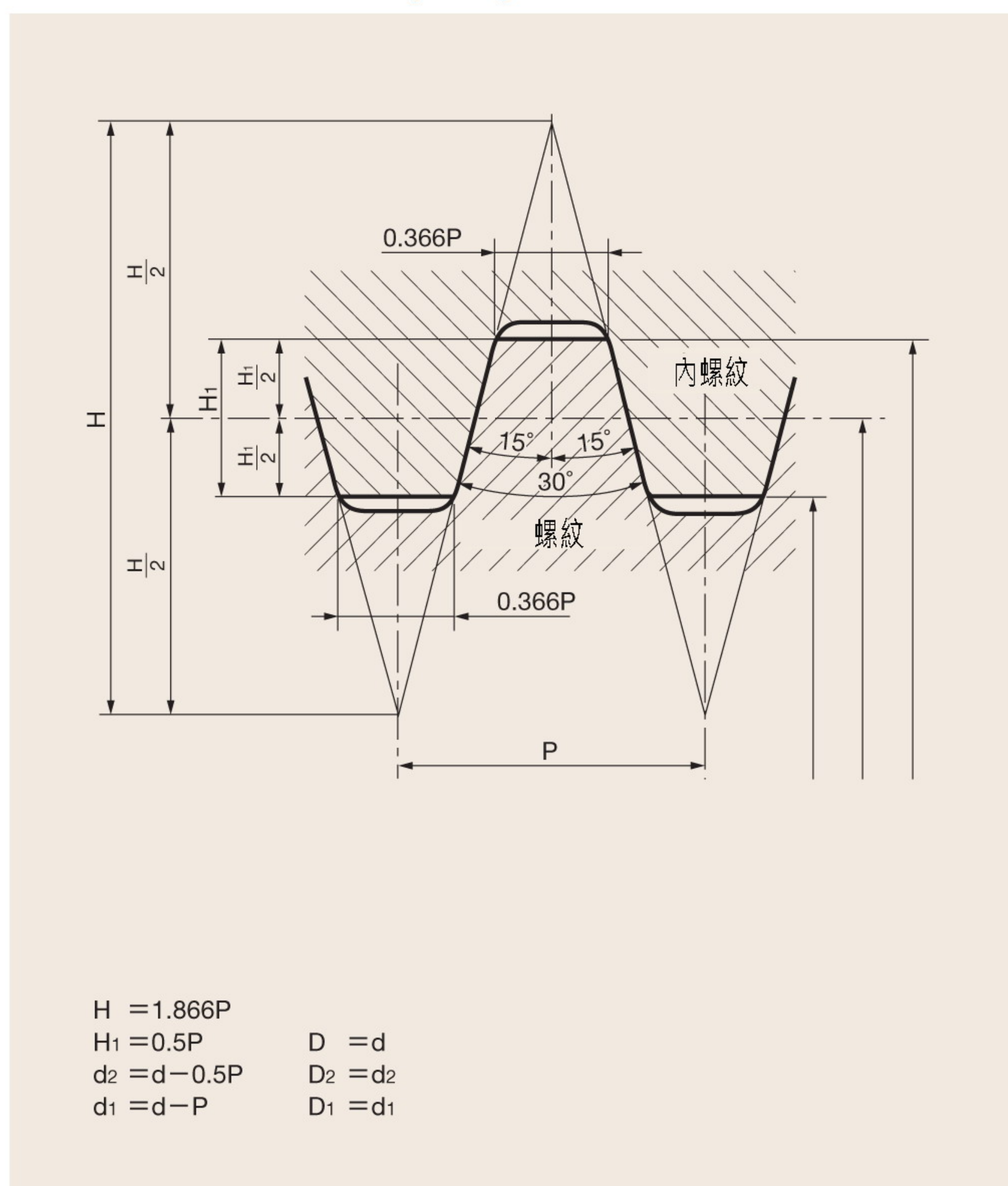

■ 29度梯形螺紋 (TW)

